

NOTE: 3' (1m) WORKING AREA SHOULD BE LEFT AROUND THE PERIMETER OF THE PRESS.

10'-8 1/2" (128.50")
(326cm)

23" (58cm)
22" (56cm)
16" (41cm)
33" (84cm)

ELECTRIC SUPPLY ON TOP

AIR SUPPLY 3/4 NPT

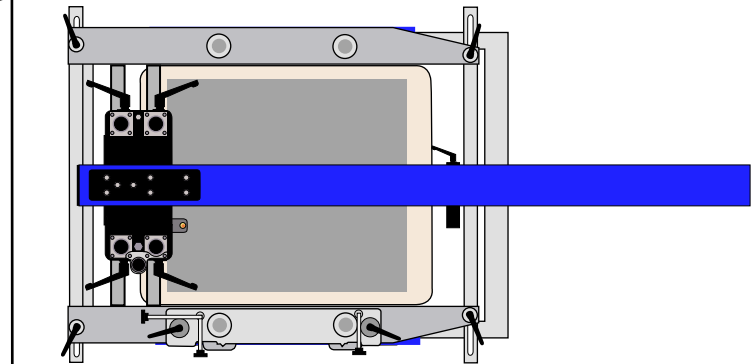

23" X 33" (58 X 84cm) OD FRAME
 DIAMONDBACK 16" X 22" PALLET
 16" x 18" (41 X 46cm) MAX PRINT *
 * MUST USE A 18" X 22" PALLET TO DO MAX PRINT AREA.

7 COLOR SHIPPING DIMENSIONS
 SHIPPING WEIGHT 3,270 lbs. (1,483kg)

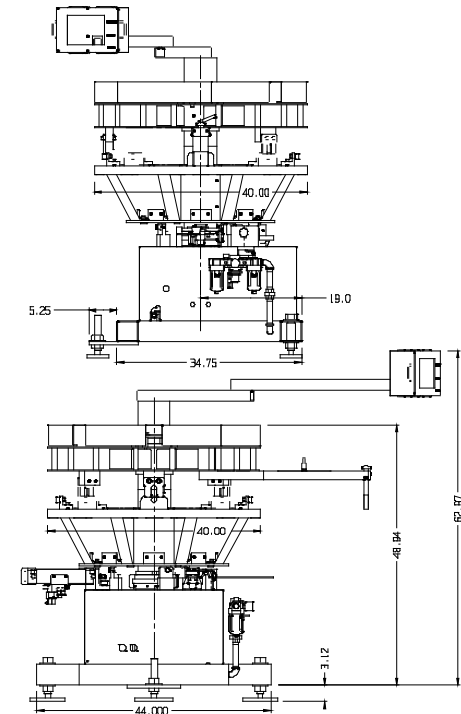

STANDARD FEATURES:

Pneumatic Index System, Pneumatic Print Heads, Screen Micro Registration, Central Off-Contact, Multiple Print Mode, Adjustable Rear Stroke, Adjustable Side Screen Holders, Revolver Program, Pallet Positioning Arm, Rubber Covered Composite Pallets, Print Start / Print finish Mode, Front or Rear Carriage stop position, Countdown Program.

See R-Series / Diamondback documentation for detailed "A" and "B" package head features.

AIR:	21.5scfm @100psi
ELECTRICAL:	110v, 1ph 1.8A, 50/60Hz, 1kW 208/230v, 1ph 1A, 50/60Hz, 1kW

